

A close-up, high-angle photograph of a metallic oil tank panel. The panel features several parallel, raised longitudinal ribs. A silver-colored bolt is visible on the left side, secured to the panel. The lighting creates strong highlights and shadows, emphasizing the texture and form of the metal.

OIL TANKS CASTED ALUMINIUM

OIL TANKS
CASTED ALUMINIUM

OIL TANKS CASTED ALUMINIUM



CONTENT

Product description / Order code	29
AB 3,5	30
AB 6,5	31
AB 12 NR	32
AB 20	33
AB 30 NR	34
AB 44	35
AB 70	36
Dimensions feet	37
Technical data	37
Dimensions oil sumps	38
General technical information	39

OIL TANKS CASTED ALUMINIUM

PRODUCT DESCRIPTION

- Low freight costs and space saving storage due to stackability
- Stable casted body with good heat dissipation by material aluminium and all-round fluting
- From AB 12 with feet and from size AB 44 optional with castors
- Flat gasket between tank lid and tank made of paperboard or rubber cork for AB 3,5 – AB 20
- Toroidal sealing ring (endless, without contact spot) 6 mm ø NBR for AB 30 – AB 70
- On request, all sizes with bores for oil level gauge
- On request, individual lid machining available at short notice



Order code			
Type	Size	Oil level gauge bores	Oil level gauge
AB	44	SB	ÖS 127
	3,5	- =>	without
	6,5	SB =>	with
	12		
	20		
	30		
	44		
	70		

OIL SUMPS

PRODUCT DESCRIPTION

- Oil sumps suitable for aluminium tanks AB 12 – AB 70
- Material S355J2 sandblasted and oil resistant primed (mineral oil HL / HLP)
- Alternative material VA, 1.4301 or 1.4571
- Approval acc. to WHG (Federal Water Act)

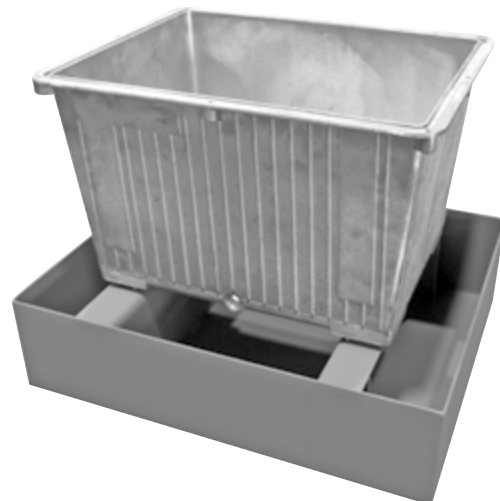

Order code	
Type	Size
ÖW	30

SERIES AB 3,5

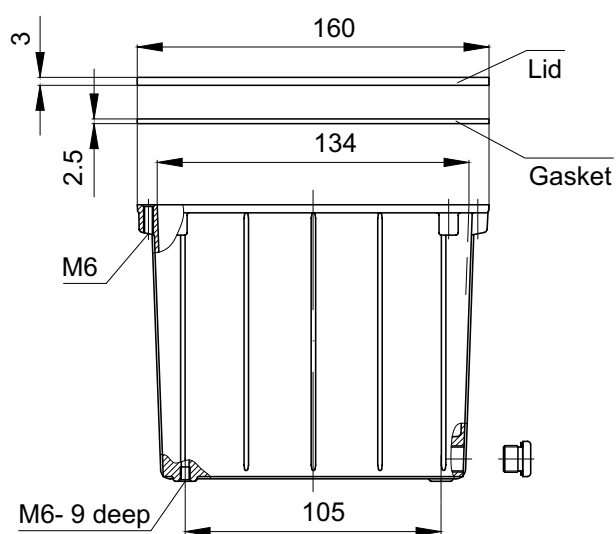
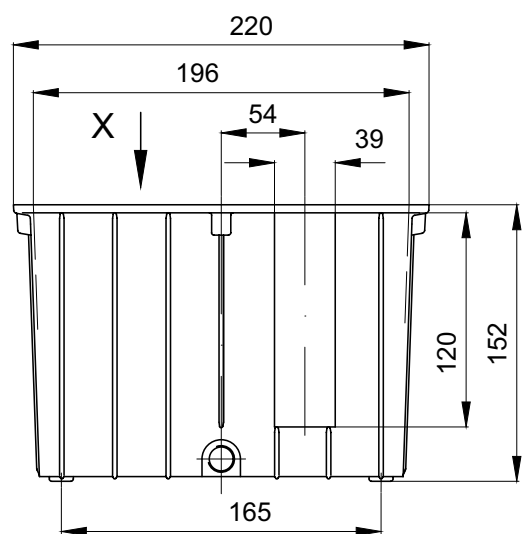

View X

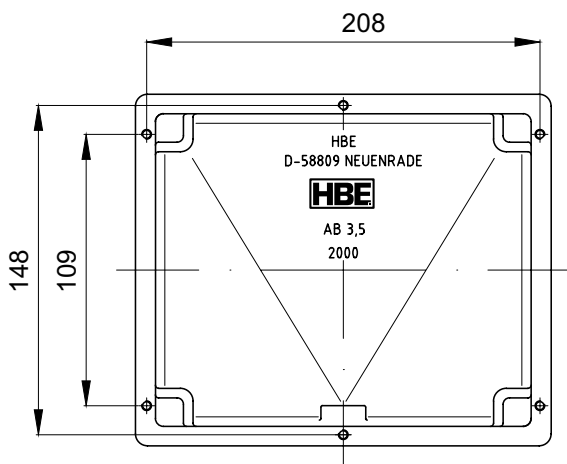

Art. No.	Type	Description
2000	AB 3,5	Tank Net volume approx. 3 L, weight approx. 1.4 kg
2200	SD 3,5	Steel lid machined for mounting on the tank, otherwise unmachined, unprimed or completely machined acc. to customer drawing
2230	D3,5 A	Flat gasket (paperboard)
2238	D3,5 GK	Flat gasket (rubber cork)
2260	AS G 1/4"	Drain plug
2261	G 1/4"	CU gasket (14 x 18 x 1.5)
2371	SE 1	Filler and breather filter (metal) ¹
2340 / 2341	ÖS 76 / ÖS 76 TH	Level oil gauge (with thermometer) ¹

¹For technical data, please see chapter "tank accessories" from page 40.

SERIES AB 6,5

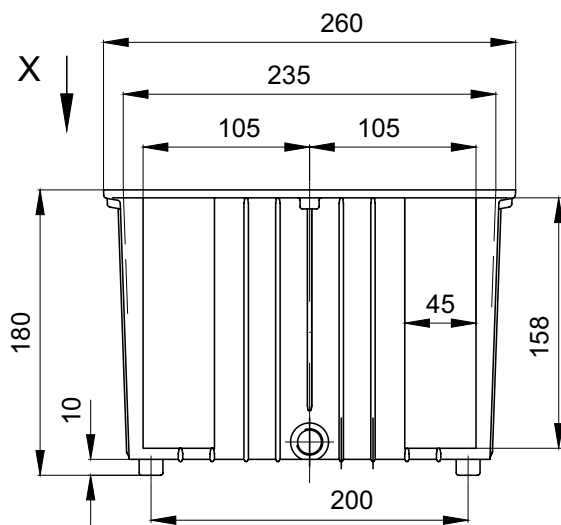

View X

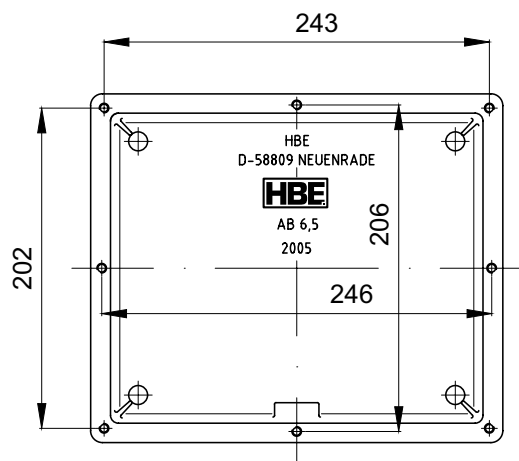
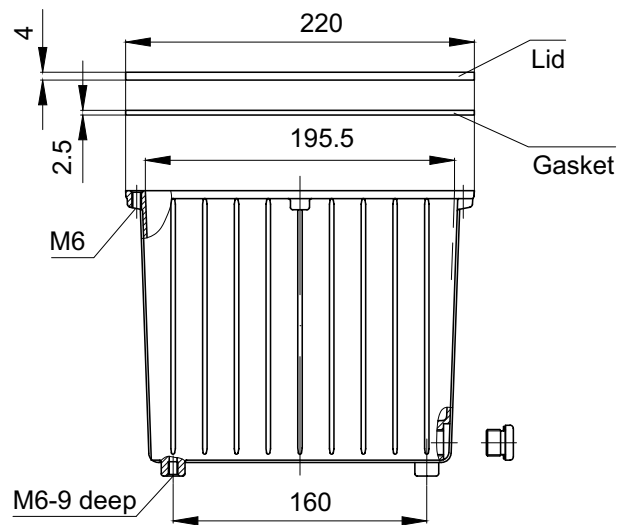

Art. No.	Type	Description
2005	AB 6,5	Tank Net volume approx. 6 L, weight 1.5 kg
2205	SD 6,5	Steel lid machined for mounting on the tank, otherwise unmachined, unprimed or completely machined acc. to customer drawing
2239	D 6,5 A	Flat gasket (paperboard)
2246	D 6,5 GK	Flat gasket (rubber cork)
2262	AS G 3/8"	Drain plug
2267	G 3/8"	CU gasket (16 x 22 x 2)
2371	SE 1	Filler and breather filter (metal) ¹
2340 / 2341	ÖS 76 / ÖS 76 TH	Level oil gauge (with thermometer) ¹
2350 / 2351	ÖS 127 / ÖS 127 TH	Level oil gauge (with thermometer) ¹

¹For technical data, please see chapter "tank accessories" from page 40.

SERIES AB 12 NR

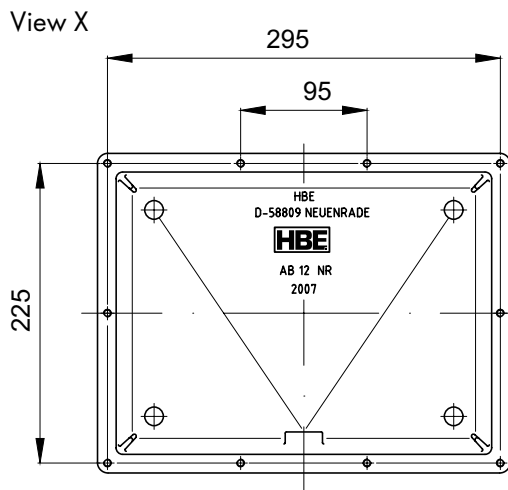
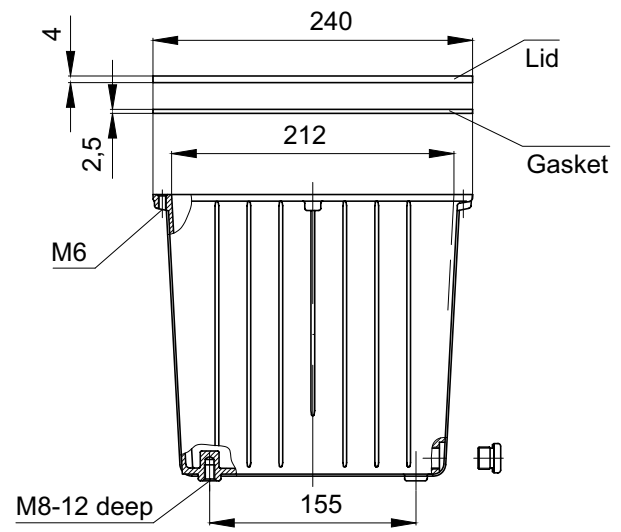
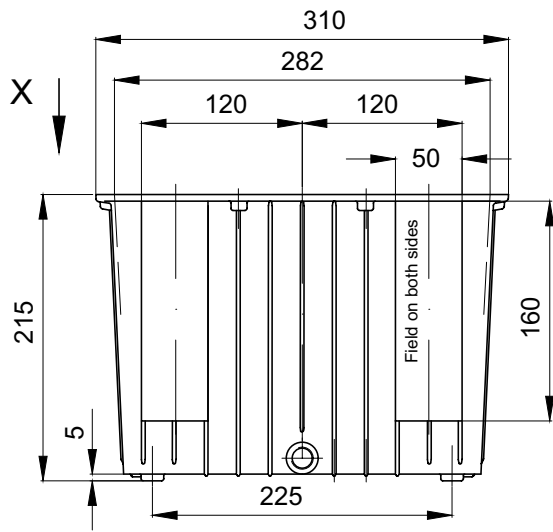

Art. No.	Type	Description
2007	AB 12	Tank Net volume approx. 10 L, weight approx. 2.2 kg
2216	SD 12	Steel lid machined for mounting on the tank, otherwise unmachined, unprimed or completely machined acc. to customer drawing
2236	D 12 A	Flat gasket (paperboard)
2240	D 12 GK	Flat gasket (rubber cork)
2262	AS G 3/8"	Drain plug
2267	G 3/8"	CU gasket (16 x 22 x 2)
2299	F 12	Aluminium feet for AB 12 (Set = 4 pcs.) ¹
2371	SE 1	Filler and breather filter (metal) ²
2340 / 2341	ÖS 76 / ÖS 76 TH	Level oil gauge (with thermometer) ²
2350 / 2351	ÖS 127 / ÖS 127 TH	Level oil gauge (with thermometer) ²

¹Dimensions can be found on page 37

²For technical data, please see chapter "tank accessories" from page 40.

SERIES AB 20

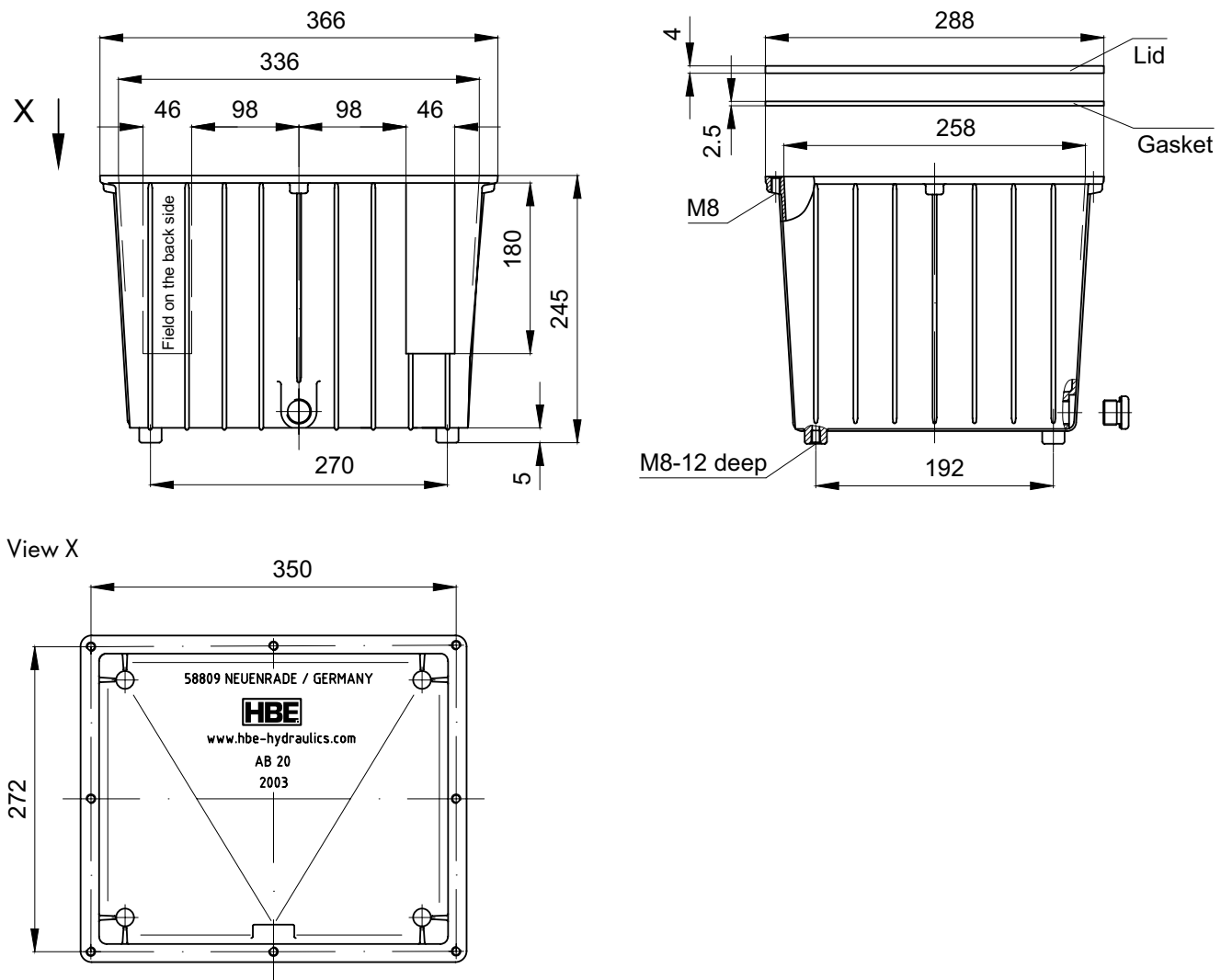

Art. No.	Type	Description
2003	AB 20	Tank Net volume approx. 17 L, weight approx. 3.8 kg
2203	SD 20	Steel lid machined for mounting on the tank, otherwise unmachined, unprimed or completely machined acc. to customer drawing
2233	D 20 A	Flat gasket (paperboard)
2245	D 20 GK	Flat gasket (rubber cork)
2263	AS G 1/2"	Drain plug
2268	G 1/2"	CU gasket (21 x 26 x 1.5)
2299	F 20	Aluminium feet for AB 20 (Set = 4 pcs.) ¹
2371	SE 1	Filler and breather filter (metal) ²
2340 / 2341	ÖS 76 / ÖS 76 TH	Level oil gauge (with thermometer) ²
2350 / 2351	ÖS 127 / ÖS 127 TH	Level oil gauge (with thermometer) ²

¹Dimensions can be found on page 37

²For technical data, please see chapter "tank accessories" from page 40.

SERIES AB 30 NR

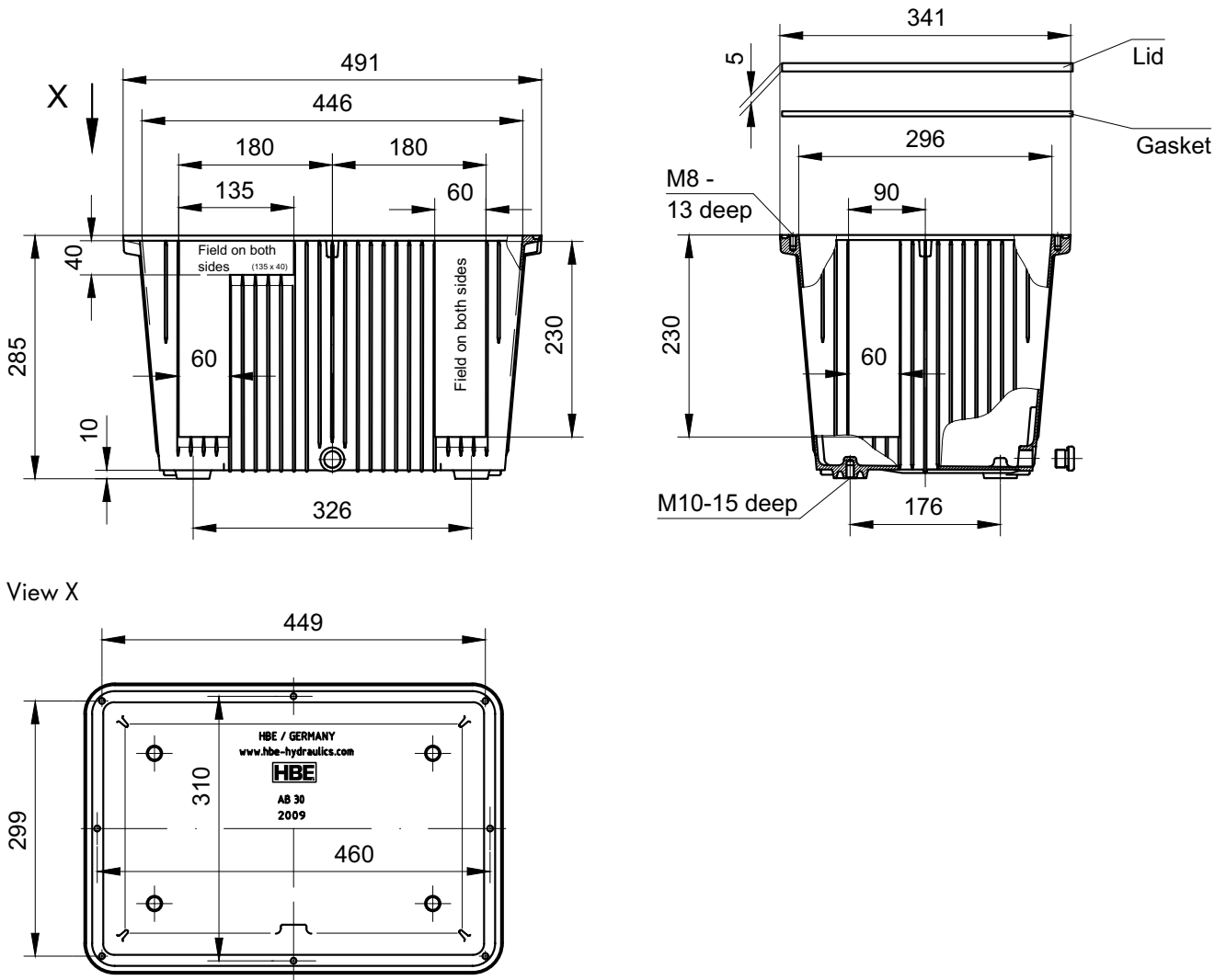

Art. No.	Type	Description
2009	AB 30	Tank Net volume approx. 27 L, weight approx. 5.5 kg
2204	SD 30	Steel lid machined for mounting on the tank, otherwise unmachined, unprimed or completely machined acc. to customer drawing
2214	AD 30	Aluminium lid machined for mounting on the tank, otherwise unmachined, unprimed or completely machined acc. to customer drawing
2234	D 30 NBR	Toroidal sealing ring \varnothing 6 mm NBR
2263	AS G 1/2"	Drain plug
2268	G 1/2"	CU gasket (21 x 26 x 1.5)
2300	F 30	Aluminium feet for AB 30 (Set = 4 pcs.) ¹
2372	SE 2	Filler and breather filter (metal) ²
2340 / 2341	ÖS 76 / ÖS 76 TH	Level oil gauge (with thermometer) ²
2350 / 2351	ÖS 127 / ÖS 127 TH	Level oil gauge (with thermometer) ²

¹Dimensions can be found on page 37

²For technical data, please see chapter "tank accessories" from page 40.

SERIES AB 44

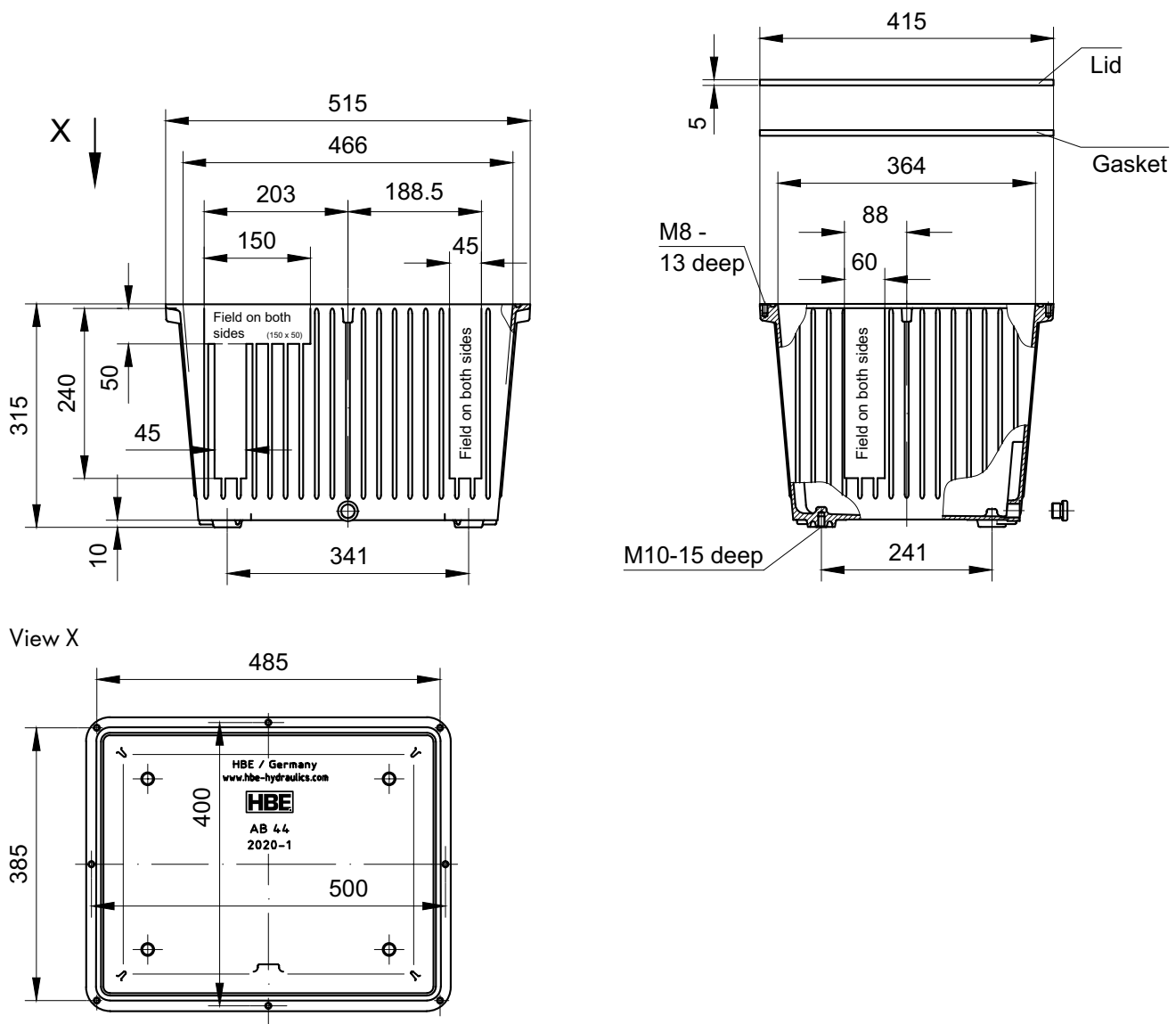

Art. No.	Type	Description
2020-1	AB 44	Tank Net volume approx. 40 L, weight approx. 7 kg
2221	SD 44	Steel lid machined for mounting on the tank, otherwise unmachined, unprimed or completely machined acc. to customer drawing
2241	D 44 NBR	Toroidal sealing ring \varnothing 6 mm NBR
2263	AS G 1/2"	Drain plug
2268	G 1/2"	CU gasket (21 x 26 x 1.5)
2300	F 44	Aluminium feet for AB 44 (Set = 4 pcs.) ¹
2372	SE 2	Filler and breather filter (metal) ²
2340 / 2341	ÖS 76 / ÖS 76 TH	Level oil gauge (with thermometer) ²
2350 / 2351	ÖS 127 / ÖS 127 TH	Level oil gauge (with thermometer) ²
2352 / 2355	ÖS 176 / ÖS 176 TH	Level oil gauge (with thermometer) ²
2384	LR 150	Castors 150 mm

¹Dimensions can be found on page 37

²For technical data, please see chapter "tank accessories" from page 40.

SERIES AB 70

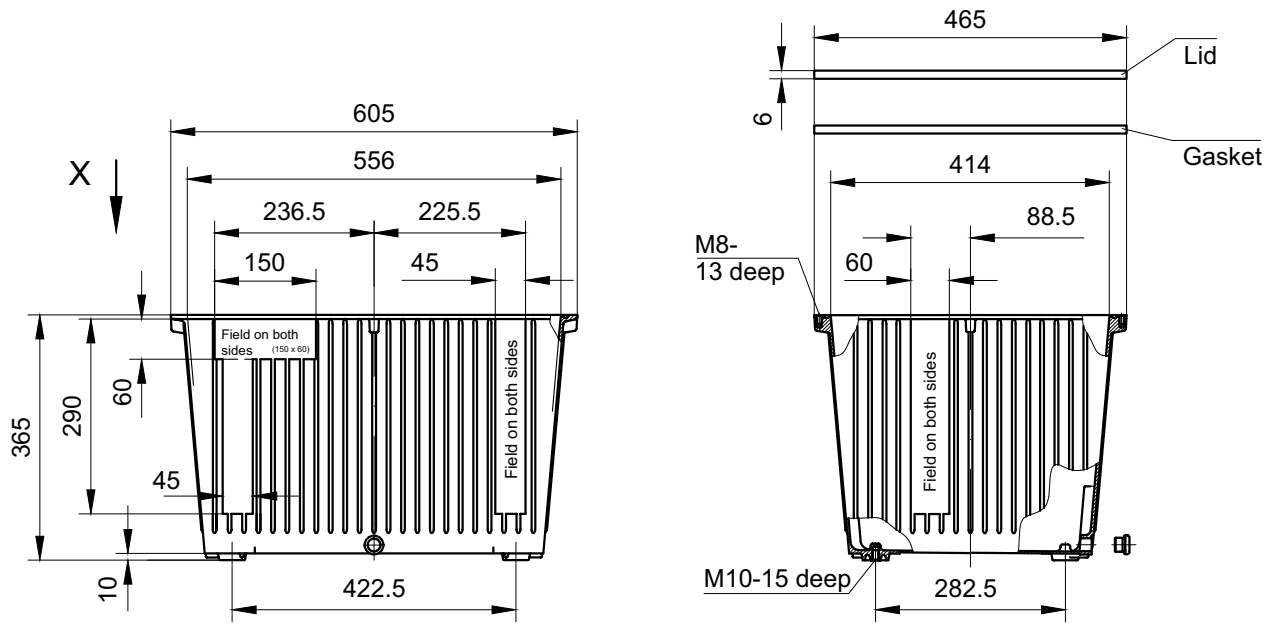

View X

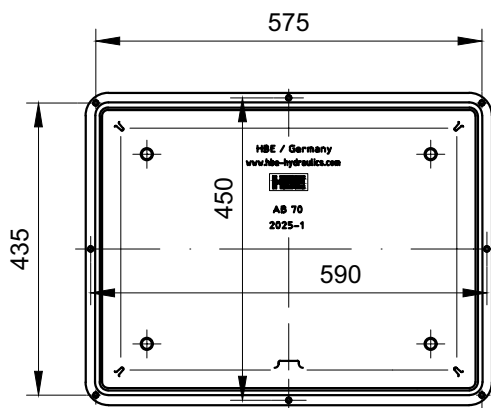

Art. No.	Type	Description
2025-1	AB 70	Tank Net volume approx. 63 L, weight approx. 9 kg
2225	SD 70	Steel lid machined for mounting on the tank, otherwise unmachined, unprimed or completely machined acc. to customer drawing
2242	D 70 NBR	Toroidal sealing ring \varnothing 6 mm NBR
2263	AS G 1/2"	Drain plug
2268	G 1/2"	CU gasket (21 x 26 x 1.5)
2300	F 70	Aluminium feet for AB 70 (Set = 4 pcs.) ¹
2372	SE 2	Filler and breather filter (metal) ²
2340 / 2341	ÖS 76 / ÖS 76 TH	Level oil gauge (with thermometer) ²
2350 / 2351	ÖS 127 / ÖS 127 TH	Level oil gauge (with thermometer) ²
2352 / 2355	ÖS 176 / ÖS 176 TH	Level oil gauge (with thermometer) ²
2384	LR 150	Castors 150 mm

¹Dimensions can be found on page 37

²For technical data, please see chapter "tank accessories" from page 40.

OIL TANKS CASTED ALUMINIUM

DIMENSIONS FEET

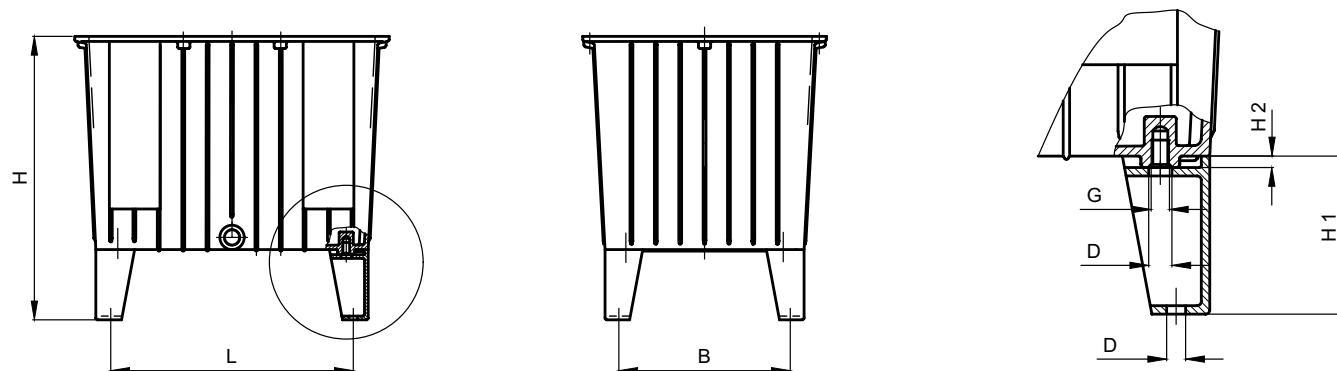

Size	Dimensions [mm]						
	L	B	H	H1	H2	G	D
AB 12	240	170	285	75	5.5	M8	9
AB 20	285	207	315	75	5.5	M8	9
AB 30	366	216	425	150	10	M10	11
AB 44	381	281	455	150	10	M10	11
AB 70	462.5	322.5	505	150	10	M10	11

TECHNICAL DATA

Size	Net volume V [l]	Specific cooling capacity P / ΔT [W/K]	Cooling capacity at ΔT = 40K P [kW]	Surface with lid [m ²]	Weight [kg]
AB 3,5	3	4	0.16	0.15	1.40
AB 6,5	6	9	0.36	0.25	1.50
AB 12	10	15	0.60	0.35	2.20
AB 20	17	18	0.72	0.50	3.80
AB 30	27	23	0.92	0.75	5.50
AB 44	40	26	1.04	1.00	7.00
AB 70	63	29	1.16	1.30	9.00

OIL TANKS CASTED ALUMINIUM

DIMENSIONS OIL SUMPS

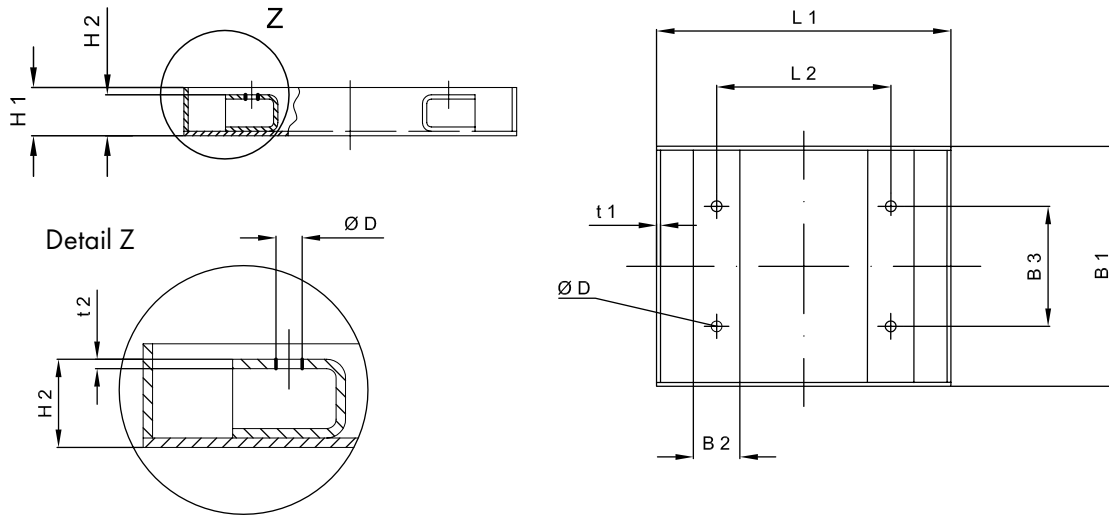

Art. No.	Type	Volume [l]	Dimensions [mm]									
			L1	L2	B1	B2	B3	H1	H2	t1	t2	Ø D
1080	ÖW 12 ST	11.8	380	225.0	310	60	155.0	110	100	3	3	9.5
1081	ÖW 20 ST	20.0	570	270.0	350	60	192.0	110	100	3	3	9.5
1082	ÖW 30 ST	33.0	550	326.0	400	60	176.0	160	150	3	5	12.0
1083	ÖW 44 ST	45.0	600	341.0	500	60	241.0	160	150	3	5	12.0
1084	ÖW 70 ST	63.5	730	422.5	580	60	282.5	160	150	3	5	12.0



GENERAL TECHNICAL INFORMATION

TABLE OF RESISTANCE AGAINST MINERAL OILS AND FLAME RESISTANT FLUIDS

Product	Material	Medium				
		Hydraulic oil / mineral oil base	HFA	HFB	HFC	HFD, HFD-R, HFD-S, HFD-T
Steel tanks	Steel	●	1	●	●	●
Gasket	NBR	●	●	●	●	●
Gasket	EPDM	●	●	●	●	●
AB tanks	Aluminium	●	●	●	●	●
Gasket	Paperboard	●	●	●	●	●
Gasket	Rubber cork	●	●	●	3	3
Lid SD	Steel	●	1	●	●	●
Oil level gauges						
with gasket	NBR	●	●	●	●	●
with gasket	FPM	●	●	●	●	●
Fillers	ST	●	●	●	●	●
Cleaning covers	Aluminium	●	●	●	●	●
with gasket	NBR	●	●	●	●	●
with gasket	FPM	●	●	●	●	●
with gasket	EPDM	●	●	●	●	●

● = Resistant

● = Not resistant

1 = Priming coat required

2 = If coating required, use epoxy resin

3 = Resistant to oil wetting

HYDRAULIC FLUIDS / MAIN COMPONENTS

HFA Oil in water emulsion, water content > 80%

HFB Water in oil emulsion, water content > 40%

HFC Watery polymer solution (water glycol), water content > 45%

HFD Synthetic fluids (water free)

HFD-R Phosphoric acid ester

HFD-S Chlorinated hydrocarbon

HFD-T Mixture of HFD-R + HFD-S

Online catalogue



epaper.hbe-hydraulics.com/en

HBE hydraulic
components

HBE GmbH
Hönnestraße 47
58809 Neuenrade / Germany
Phone +49 (0) 23 94 / 616-0
info@hbe-hydraulics.com
www.hbe-hydraulics.com



A company of
e.holding
FLUID TECHNOLOGY GROUP

09/23 www.plakart.de